

FTC

FIBER TECHNOLOGY
CORPORATION

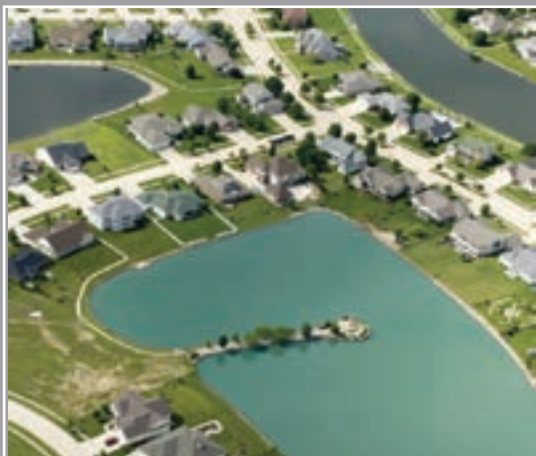

FRP PANEL TYPE WATER TANK

Pure water storage system

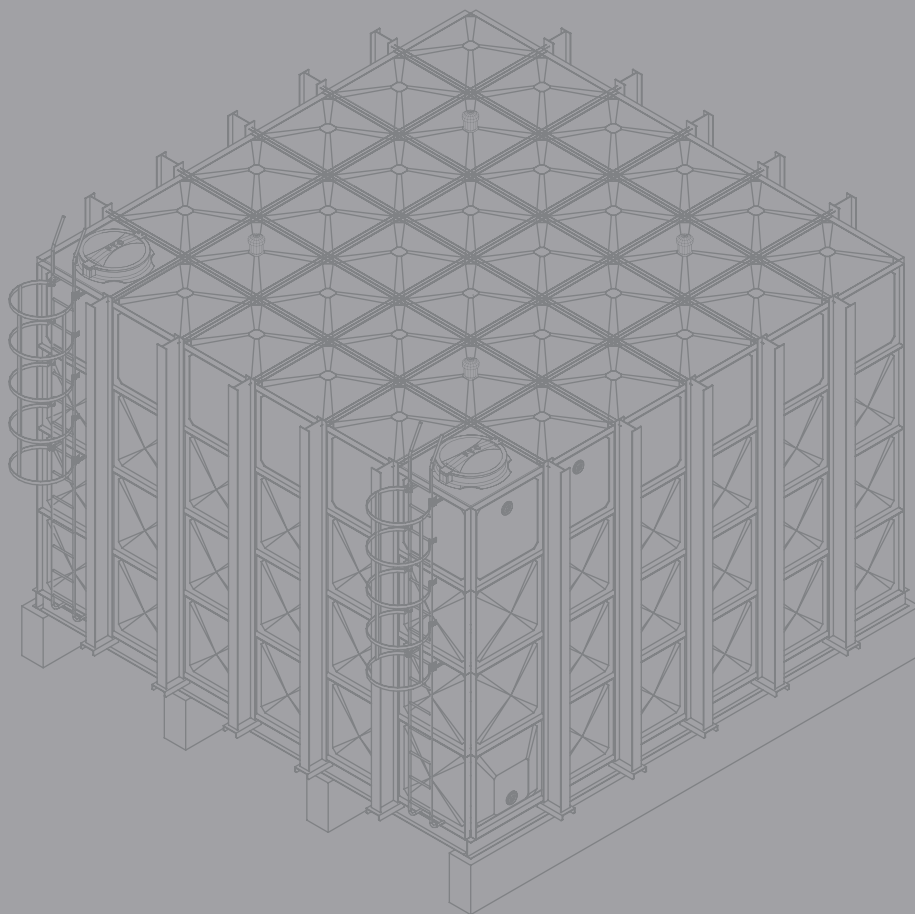

ISO 9001
BUREAU VERITAS
Certification



WRAS
APPROVED
PRODUCT



FTC. Who we are.

Fiber Technology was incorporated in 1992 in Virginia, USA, to provide innovative water storage solutions and address the shortcomings inherent to traditional storage systems. A vision of maintenance-free clean water storage became the key driver to product development.

We focus our worldwide marketing efforts on the advantage of storing water hygienically for extended periods of time.

To complement our worldwide services, and for timely turnaround on global projects, we established, in 1998, a distribution center in Dubai, UAE.

Fiber Technology Corporation manufactures premium quality water tanks of the highest specification and hygiene standards. It offers tank sizes ranging from 260 USG (1 m³) to 2,500,000 USG (10,000 m³) and more for the direct and indirect water supply markets around the world. Our products are certified in the USA to NSF 61 Annex G certified, and are in compliance with the most notable water standards globally.

FRP PANEL TYPE WATER TANK

Pure water storage system

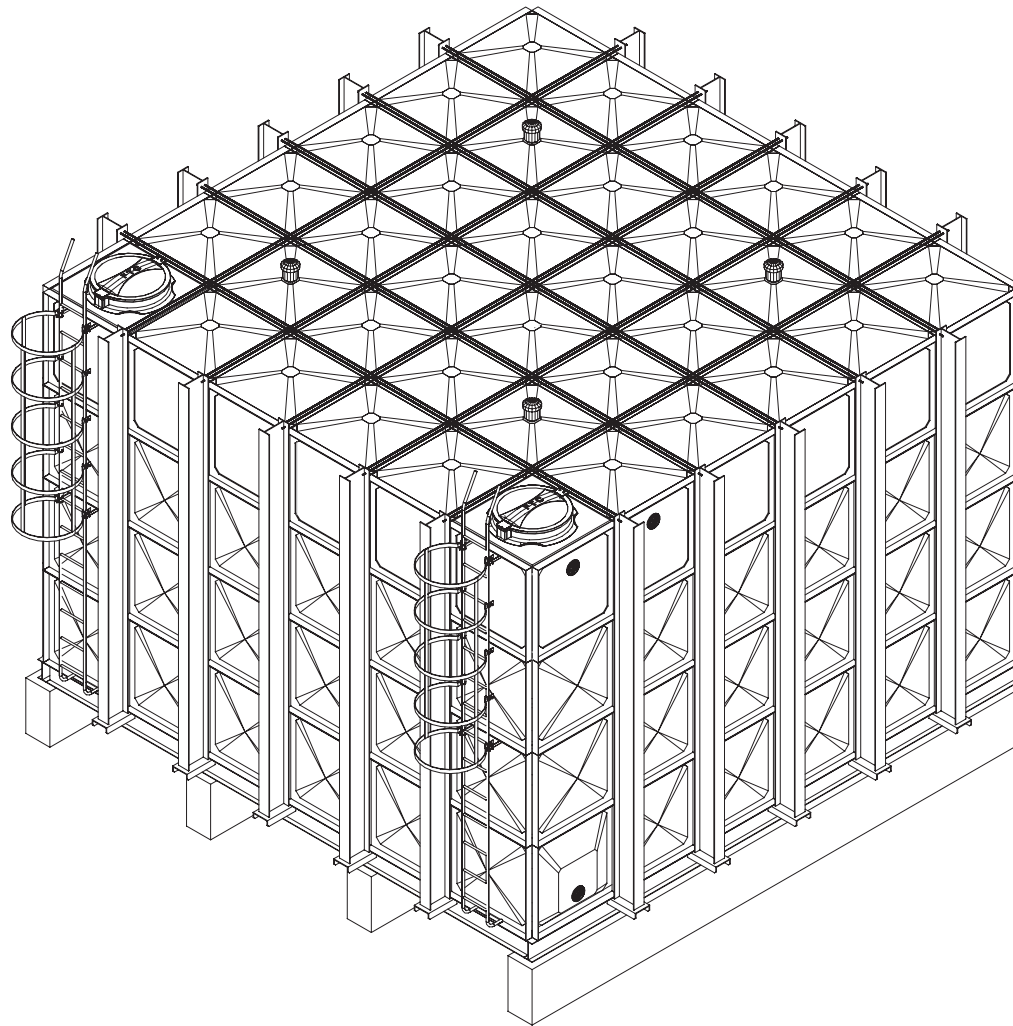

Certified to
NSF/ANSI 61-G



TABLE OF CONTENTS

6 FTC. Who we serve

8 The FRP panel type water tank

- The water storage system
- The FRP advantages

14 Long term reliability

16 Certifications and Standards

18 Structure of the insulated panel

20 Strength and durability

22 Prevent leakage - by design

24 Adaptability

26 Environmental

30 Step-by-step assembly



32 Convenient self-assembly kits

34 Perfect flexibility

36 Standard panel patterns

38 Technical data

40 Steel footing design

42 Concrete foundations

43 Details and dimensions of tank and pipework connections

44 Flange dimensions for tank capacity

46 Picture gallery

48 Steel towers for elevated tanks

50 Components and accessories



FTC. WHO WE SERVE





FTC FRP Panel Type Water Storage Tanks are versatile due to their modularity, low maintenance, excellent thermal and hygienic properties. Our tanks can be utilized as : Potable Water Storage, Rainwater Tanks, Rural Well Water Tanks, RO and Seawater Desalination Tank, Processing Tanks, Fire Water Storage Tanks, Brown/Grey Water. Servicing industries such as : Government, Local Municipalities, Hospitals, Education, Food Processing, Manufacturing, Hospitality.

The low maintenance features, zero light penetration, stable thermal transition, and hygienic quality make **FTC** FRP Panel Type Water Tanks superior for potable water tank Storage.

Although our tanks are primarily designed to store drinking water it is often used in other water and liquid storage applications. Consult with a representative to see if **FTC** FRP Panel Type Water Storage Tanks can be applied to your next project.

THE FRP PANEL TYPE WATER TANK

“No metal in contact with water”

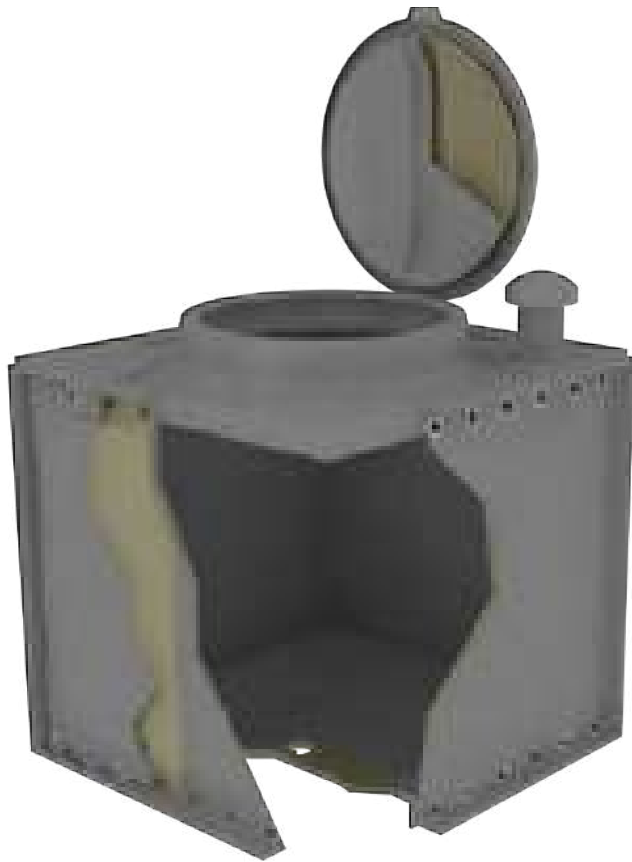

Insulated Tank



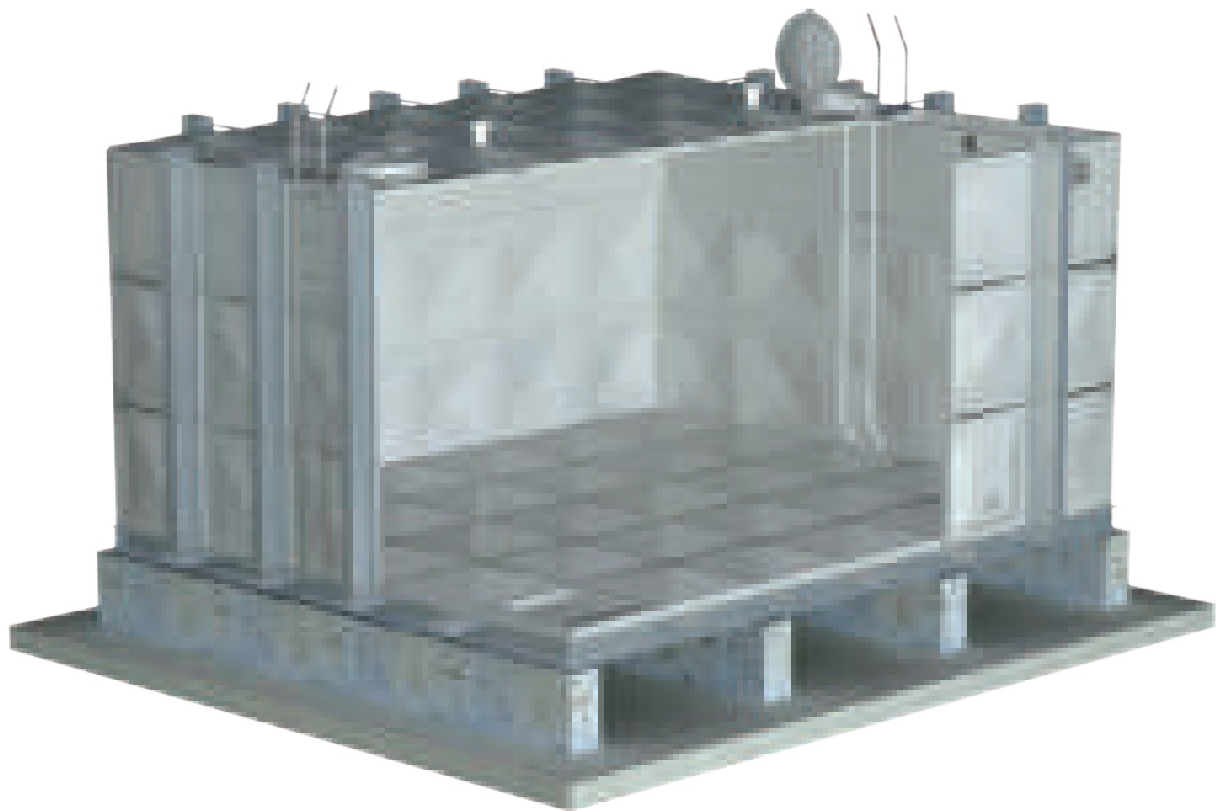

Interior Cut Out View



2 Meter High Panel Tank.

THE WATER STORAGE SYSTEM

“Managing the world’s water supply”

It is an obvious fact, which nonetheless deserves emphasizing, that water is fundamental to our daily lives. Whether for drinking, cooking, washing or cleaning, as well as industrial and commercial requirements. As demand grows year by year, the management and conservation of supplies becomes ever more critical, the highest standards of purity of the delivered product are insisted upon.

The **FTC** FRP Panel Type Water Tanks storage system has been designed and developed for the single purpose of meeting these demands, efficiently and flexibly, with uncompromising levels of quality and reliability. Specified to meet the most rigorous conditions, it has become the system of choice around the world for applications from individual homes to major building and industrial complexes.

The **FTC** FRP Panel Type Water Tanks system is supremely flexible. Small units, from 1m³ (260USG), serve as an integral element at the point of use in a piped delivery system. Larger units, even up to 10,000m³ (2,500,000USG), provide free-standing long term storage capacity.

All conserve water to the highest quality standards, serving the needs of private residences, accommodation complexes, hospitals, hotels and offices, as well as industrial, municipal and irrigation projects where large-scale water storage is required. Every unit is supplied to the same standard of design and



specification, to the size and shape best suited to every need of the customer. Assembly and installation is straight forward, and may be carried out by the user or his contractor, or where preferred, by appointed **FTC** suppliers.



THE FRP ADVANTAGE

*“Pure, clean water.
Always”*

Pure, clean water at all times and for all purposes – drinking, domestic or industrial – is what the **FTC** FRP Panel Type Water Tank is designed to deliver. The specifications and exclusive design features of the system protect against any occurrence of static water, growth of algae, contamination from corrosion or bacteria, or accumulation of externally introduced material.

NO ALGAE GROWTH. The growth of algae and other micro-organisms is closely related to light. To prevent this requires light transmission of less than 0.1% in direct sunlight.

All standard **FTC** FRP Panel Type Water Tanks molded panels have a light transmission of less than 0.005%, to prevent algae growth even if the tank is installed in full sunlight. Growth of algae, if allowed to occur, will adversely affect water taste, and can lead to disease such as gastro-enteritis.

NO BACTERIAL GROWTH. All **FTC** FRP Panel Type Water Tanks are hot press molded with perfectly smooth finish, eliminating the problem at the source. Conventional tanks allow stored water to be in contact with rough surfaces, this creates a breeding ground for bacterial growth.

Chlorination of water is frequently used as a bactericidal agent, but this loses effect after a few hours unless the water is constantly replenished. Bacteria which successfully proliferate on a rough surface develop a protective bio-film. This film eventually breaks down, and U.S. studies have shown that the by-products in the presence of chlorinated water can produce potentially carcinogenic agents.

MINIMAL CLEANING REQUIREMENT. The smooth interior surfaces, and free-draining design, of the **FTC** FRP Panel Type Water Tanks minimizes any opportunity for pollutants, whether originating internally or externally, to develop and accumulate. Routine cleaning requirements are consequently simple and infrequent, with no risk of leaving residual material or cleaning agents inside the tank.

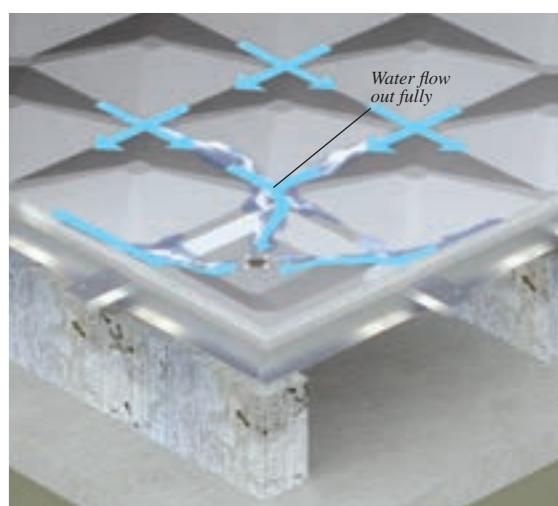
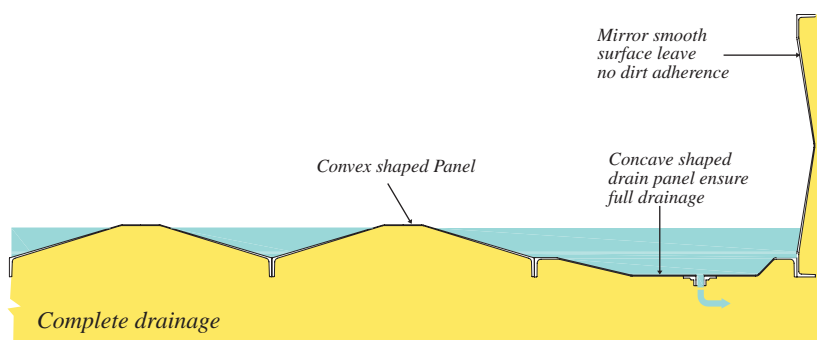

Complete drainage

COMPLETE DRAINAGE. The base of the **FTC** FRP Panel Type Water Tank is constructed with convex bottom panels. This not only provides a positive sealing pressure, which increases as the water height increases, but also enables a free flow of water from all parts of the tank to the concave drainage panel. Complete and fast drainage from the lowest point is thus ensured, with no possibility for static water to accumulate and become stale or contaminated.

LONG TERM RELIABILITY

DESIGN.

RIGOROUS TESTING. Computer aided panel design, allied to the immense inherent strength of FRP material combined with the resilience of a flexible joint system, makes **FTC** FRP Panel Type Water Tanks unmatched in the world for reliability. The tank design has been rigorously tested and experimented for the worst environmental conditions. Exposed to ensure a reliable design under all conditions.

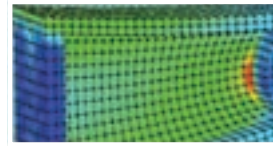

QUALITY – RAW MATERIAL SUPPLIES / CERTIFICATION

All raw materials used in the manufacture of **FTC** FRP Panel Type Water Tanks are agreed to with quality guidelines and parameters to suppliers. All deliveries are batch tested and crosschecked with supplier quality data before entering the production environment. Our manufacturing facility is ISO 9001 certified and we have many regional Water Certifications such as NSF 61 Annex G, ASNZS4020 and many more.



FLEXURAL STRENGTH

Flexural strength, also known as modulus of rupture, bend strength, or fracture strength, is defined as a material's ability to resist deformation under load. The transverse bending test is most frequently employed, in which a rod specimen having either a circular or rectangular cross section is bent until fracture using a three point flexural test technique. The flexural strength represents the highest stress experienced within the material at its moment of rupture.

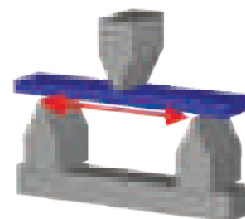

“Our in-house laboratory performs all relevant testing related to the tank material”



TENSILE STRENGTH

Ratio of the maximum load a material can support without fracture when being stretched to the original area of a cross section of the material. When stresses less than the tensile strength are removed, a material completely or partially returns to its original size and shape. As the stress approaches that of the tensile strength, a material that has begun to flow forms a narrow, constricted region that is easily fractured. Tensile strengths are measured in units of force per unit area.

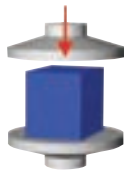

COMPRESSIVE STRENGTH

It is the capacity of a material to withstand axially directed pushing forces. When the limit of compressive strength is reached, materials are crushed.



IMPACT STRENGTH

The amount of energy required to fracture a material; a measure of the material's resistance to mechanical shock.



BARCOL HARDNESS

The Barcol hardness test characterizes the indentation hardness of materials through the depth of penetration of an indenter, loaded on a material sample and compared to the penetration in a reference material. The method is most often used for composite materials such as reinforced thermosetting resins or to determine how much a resin or plastic has cured.

CERTIFICATIONS & STANDARDS

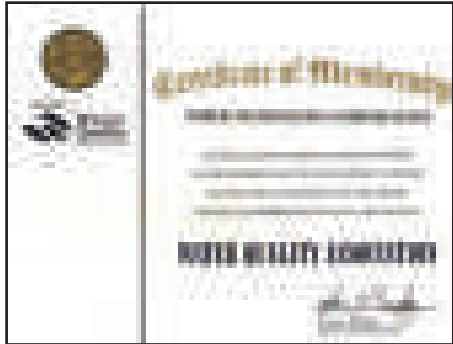

FTC FRP Panel Type Water Storage Tanks and its components are extensively tested and certified and comply to the world's premier certification and/or standards requirements, to enable installations anywhere in the world.

			<p>ISO 9001 NSF 61 Annex G WRAS AS/NZS 4020</p>
			<p>ASTM D1201 ASTM D578 ASTM D570 ASTM D638 ASTM D695 ASTM D696 ASTM D732 ASTM D790 ASTM D792 ASTM D5930</p>
			<p>AWWA D12X:XX CIBSE TM13 CSA B126 BS EN 13280</p>
	<p>FTC FIBER TECHNOLOGY CORPORATION</p>		<p>BS 6700 BS 7491 BS EN 1998-4:2006 Eurocode 8 JIS A 4110:1989 NFPA 22</p>

STRUCTURE OF THE INSULATED PANEL

In winter conditions, even in temperate climates, a serious risk of freezing exists, with consequent damage and disruption to supplies. On the other hand, in hot summer conditions, water temperatures tend to increase to levels making domestic use and showering very unpleasant.

To solve these issues the fiber reinforced plastic FRP, from which the **FTC** FRP Panel Type Water tank molded panels are fabricated, is an excellent insulator with very low thermal conductivity approximately two hundred and forty times lower than steel-minimizing the risk in normal conditions.

Where a tank may be exposed to consistently low/high temperatures, panels which incorporate additional insulation can also be specified, to further reduce any risk of freezing.

THE INSULATED PANEL

The **FTC** FRP Panel Type (1) tank insulated panel has rigid polyurethane (PU) foam, of low thermal conductivity, sandwiched between inner FRP layer and outer Resin cover, as shown. These composite panels are used on the sides and base of the tank, which are directly in contact with the water. Additional protection is not required for the roof of the tank, since a static air layer between the water surface and the tank provides good insulation.



Extreme Cold Weather (-40°C)



Extreme Hot Weather (+55°C)

*“Insulation from
excess temperature
variation”*

*Insulation 25mm.(1inch)
(Rigid polyurethane foam)*

On Request 50mm.(2inch)

ASA Sheet Cover

FRP Panel



STRENGTH AND DURABILITY

The FRP material, from which all the **FTC** FRP Panel Type Water Tanks are manufactured, is light, corrosion – free and highly durable, very strong in both tension and compression, and rigid. Unlike steel, it has a low coefficient of expansion, minimizing stress at all fixings caused by temperature variations. Design criteria for all tanks, summarized in table, established a massive 8 times safety factor of panel strength over maximum anticipated load – proof against the worst natural disasters of the last 100 years.

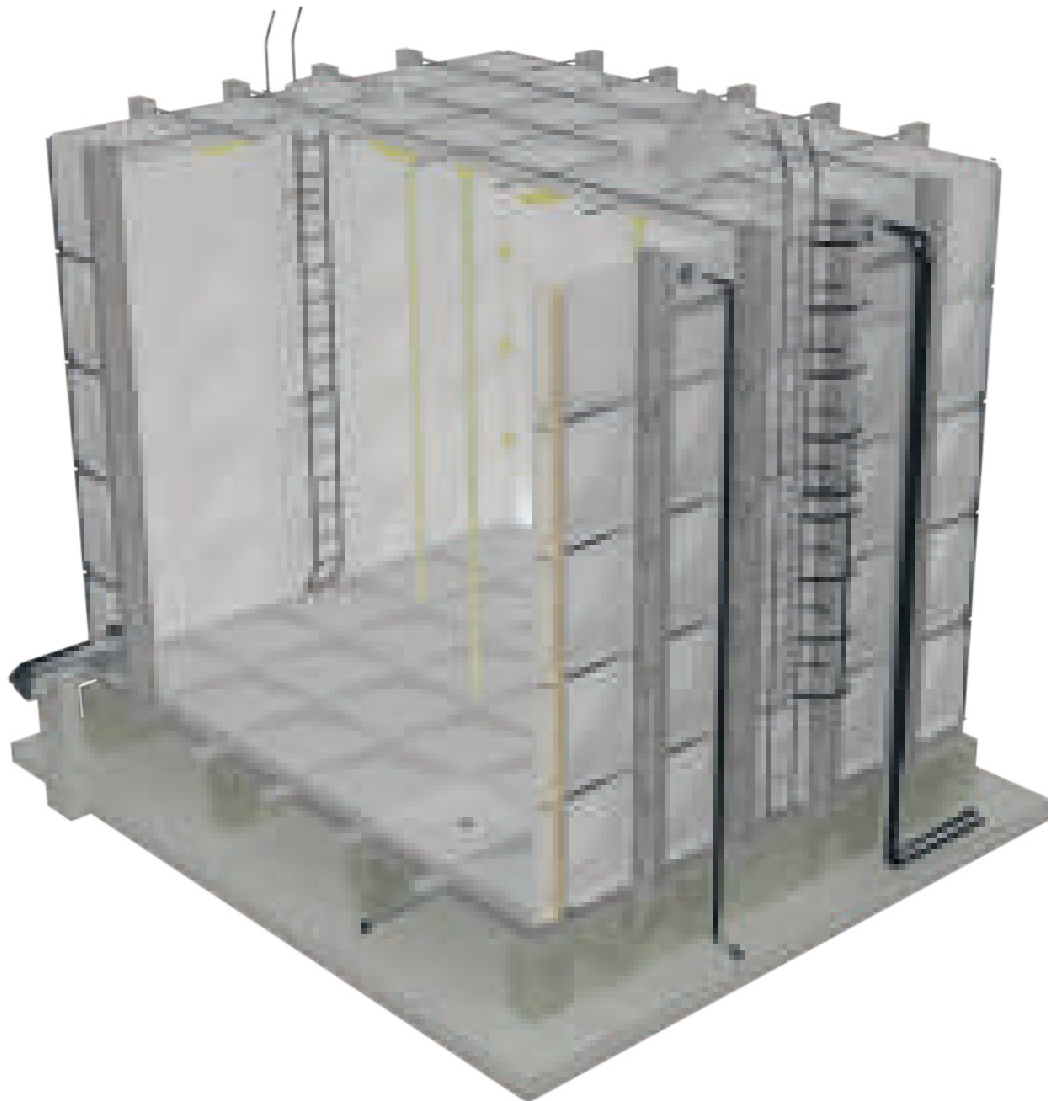

DESIGN CONDITIONS	Hydrostatic Pressure						
	Depth of tank		Panel strength		Hydrostatic pressure		Safety factor
	(m)	(ft)	(kgf/cm2)	(Psi)	Kgf/cm2)	(Psi)	PS/HP
Wind Velocity 60m/sec. 134 mph							
Snow load 60kgf/m2 or 12.3 lb/ft2							
Main load 120kgf or 265 lb							
Seismic load Horizontal Seismic Coefficient Kh=0.3	1	3.3	.06	8.53	0.07	1	8.53
Water temperature 60°C (max) or 104°F, this could be increased to 80°C or 176°F with special sealant.	1.5	4.9	1	14.52	0.12	1.7	8.54
Anchor bolts shall be used to tie down a tank at the designed points.	2	6.5	1.3	18.5	0.16	2.28	8.11
Note:	2.5	8.2	1.7	24.2	0.21	2.99	8.09
1. Panel strength is the actual 'bursting' pressure	3	9.8	2.1	29.9	0.26	3.7	8.08
2.Design can also be made for Kh 2/3, 1.0 and 1.5	3.5	11.5	2.5	35.56	0.31	4.41	8.06
	4	13.1	2.9	41.25	0.36	5.12	8.06



PREVENT LEAKAGE BY DESIGN

The convex base panels transmit water pressure to the panel joints, increasing the sealing pressure as water level increases.

The joints themselves are further sealed with a flexible rubber sealant, developed from advanced technology in rubber products, which maintains its' properties in all temperatures.

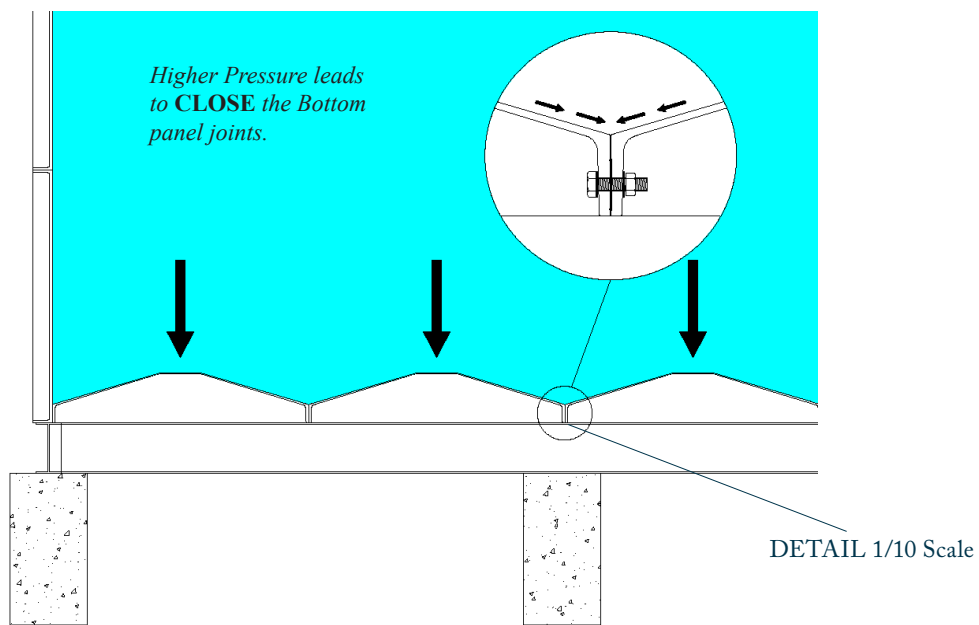

FTC Bottom Panels Improve Seals

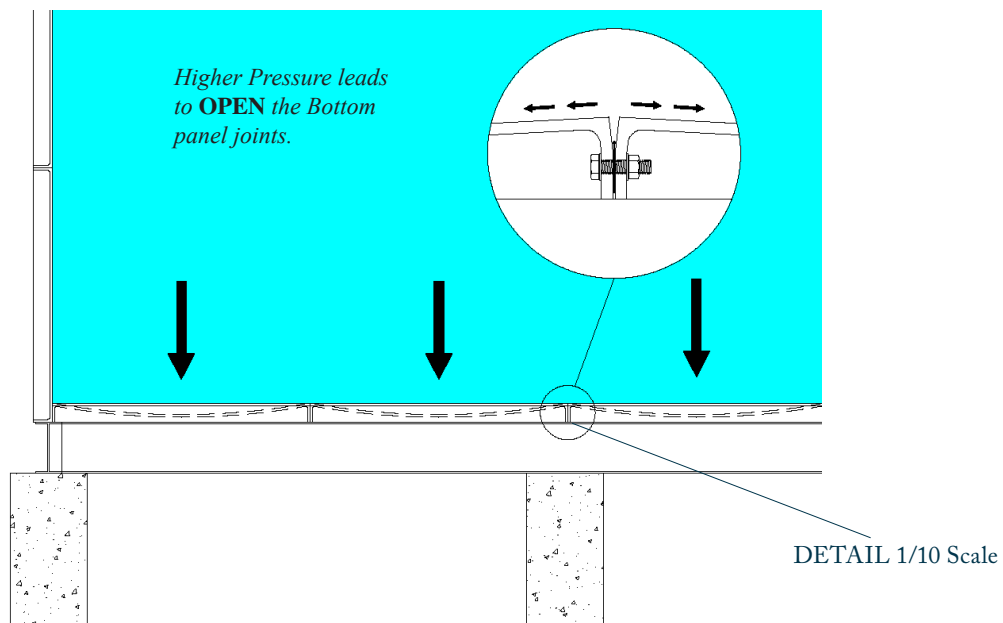

Other Tanks Bottom Tend to open on Pressure

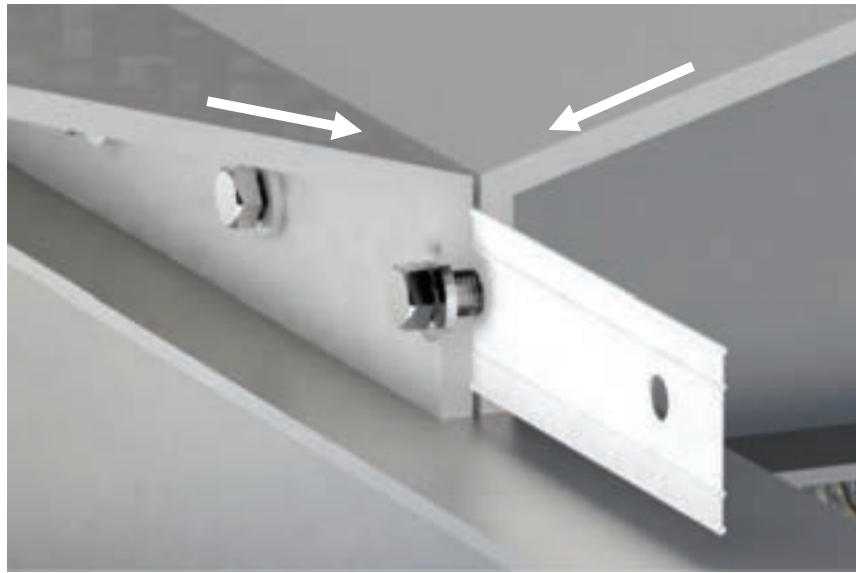

"O" Ring type SEALANT acts as 4 water barriers to leakage.

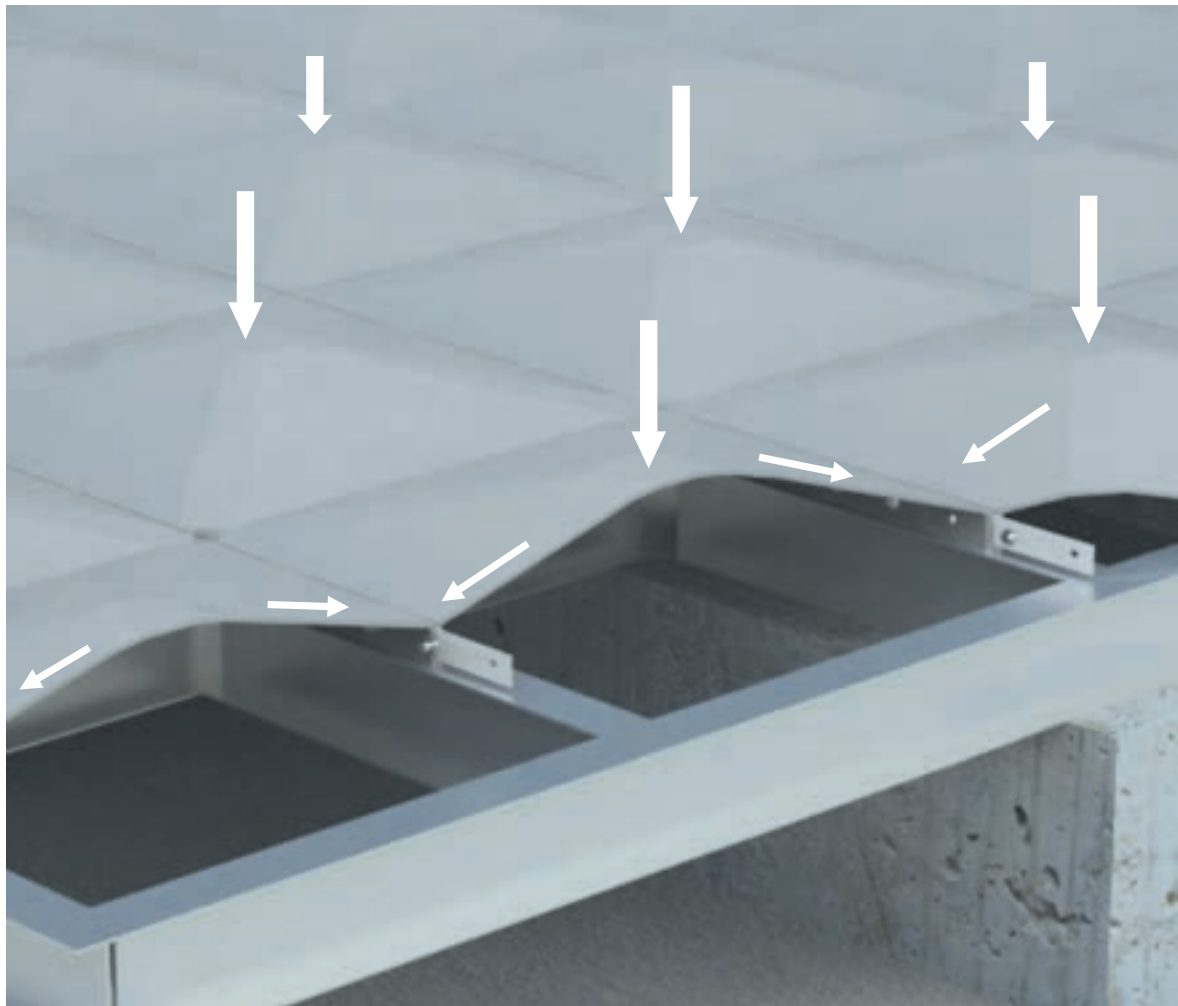

Water Pressure Improve Joint SEAL.

ADAPTIBILITY

ADAPTABILITY – MULTI USE

FTC FRP Panel Type Water Tanks are primarily designed to store potable water, due to its exceptional strength and modular design it can be used as a fire tank at the same time with different outlet levels.

The tanks have also been successfully deployed as sea water intake tanks, surge tanks, balancing tanks, grey water storage, retention runway tanks, recycled/reuse water tanks, irrigation tanks, rainwater tanks, industrial process water tanks, chilled water storage, warm water storage, etc..

FTC FRP Panel Type Water Tanks could also be used to certain chemical with additional and/or other optional material modifications on demand.

FTC FRP Panel Type Water Tanks are well suited for either outdoor or indoor, and is particularly useful in established structures with limited access to either supply new storage or to replace older tanks.

ADAPTABILITY – SEISMIC, SNOW, WIND LOADS

FTC FRP Panel Type Tanks can be delivered to cover the most severe specification needs, on demand to be able to withstand seismic zone 4, high snow and/or wind load specifications.



FTC tanks designed to assume some of the worst conditions.

ADAPTABILITY – SHAPE & SIZE INVESTMENT PROTECTION

COMPLEX SHAPE

FTC FRP Panel Type Water Tanks can be configured to be assembled with square, rectangular, L or U shaped configurations to make full use of available space.

EXTENDABLE

FTC FRP Panel Type Water Tanks can also be partitioned or have baffles inside in order to have separate operating compartments or for water flow characteristics.

PARTITIONS & BAFFLES

Due to the modular nature of our **FTC** FRP Panel Type Water Tanks it can also be extended by adding more panels in future when more capacity is required.

RELOCABLE

FTC FRP Panel types water tanks could be relocated to another location even after years of usage. Simple un-bolting and rebolting procedures are required.



ENVIRONMENTAL

Green Conscious

The world is showing an increased awareness of environmental issues when selecting materials for construction or otherwise. The concept of “Green Buildings” is slowly becoming the norm rather than the exception. Recyclability, sustainability and carbon footprint impacts are becoming important considerations when designing infrastructure and building. The life cycle of a water tank from manufacture through to its disposal is becoming the approach to choosing the most suitable tank for a building or outdoors.

Our externally reinforced **FTC** FRP Panel Type Water Tanks offer significant environmental benefits – they weigh less and require less energy to transport and install than equivalent steel tanks, they have excellent mechanical properties and are corrosion free. Design life is in excess of 40 years and over this time, maintenance requirements will be minimal.



Approved For Potable Water

FTC FRP Panel Type Water Tanks are approved for potable water with many regional approvals such as USA (NSF61), AWWA, AUS (ASNZS4020), Canada (CSA B126), UK (WRAS) and many others. Awareness of VOC emissions (volatile organic compounds) however has prompted some clients to seek more information about FRP. There are various forms of FRP (also known as GRP). The FRP used to manufacture **FTC** FRP Panel Type Water Tanks is a composite made from a compound called SMC(Sheet Mold Compound); the panels are formed by compression molding which is a combination of pressure and heat in a closed matched metal mold, during the compression molding process the panel becomes fully cured.

The process eliminates any toxic potential a prevalent phenomenon called “outgassing” that occurs with lesser cured manufacturing technologies. This process also results in minimal material wastage and is low in energy inputs, at our ISO 9001:2008 Certified Facility.

No Mess Or Waste On-Site

Every **FTC** FRP Panel Type Water Tank is a pre-engineered bolted on the outside with no metal in contact with water system, and pre-packed to the specific requirements of the client. The tank components packed on pallets and shipped to site for assembly. There is no need for cutting or welding on site and all materials are used in the installation, leaving behind a clean and safe site with zero wastage.

More Energy Efficient

Embodied energy refers to the amount of energy required to manufacture and supply to the site of use of a product through to its destruction and decomposition. In a recent case study⁽¹⁾ of steel, aluminum, stainless steel and FRP for the construction of a bridge in The Netherlands, the environmental analysis of embodied energy put FRP as a clear winner. A steel, aluminium and stainless steel all resulted in more than twice as high energy consumption.

As far as pollution impacts, again the FRP option scored best, with structural steel second and aluminum third. The final decision on choice of material for the bridge structure was based on ecological factors and the FRP option was confirmed. Installation of the bridge took place in October 2001.

Highly Recyclable

Externally reinforced **FTC** FRP Panel Type Water Tanks have a design life in excess of 40 years. It is likely the tank will last well after this time, with minimal maintenance during its lifecycle required. Ultimately, the steel supports and the GRP panels can be completely recycled as scrap or put to other uses.

(1) <http://www.reinforcedplastics.com/view/2799/the-business-case-for-composites-in-construction/>

ENVIRONMENTAL



KROON HALL

The new School of Forestry and & Environmental Studies at Yale sets a new standard for sustainability on campus.



KROON HALL School of Forestry and Environmental Studies at Yale University in New Haven, Connecticut, USA⁽¹⁾ was designed to consume half the energy of an equivalent academic building and reduce greenhouse gas emissions by 62 percent—is targeted to achieve LEED Platinum.

FTC FRP Panel Type Water Tanks form the heart of the rainwater harvesting system that is expected to save more than 500,000 gallons of potable city water per year.

(1) <http://www.architectmagazine.com/sustainability/kroon-hall.aspx>

Environment & Life Cycle Analysis

Ecological calculations were performed according to the ISO 14040, while the proprietary methodology of the LCC (eco-efficiency analysis), and were used to quantify the environmental cost of the various products.



Determining the environmental impact according to ISO, 6 main variables were considered: consumption of raw materials, consumption of energy (including utilization), emissions (to air, water and soil), land use, toxicity potential of substances employed and substances produced, potential for misuse and potential risk. These variable parameters are weighted and combined to give an impact score.

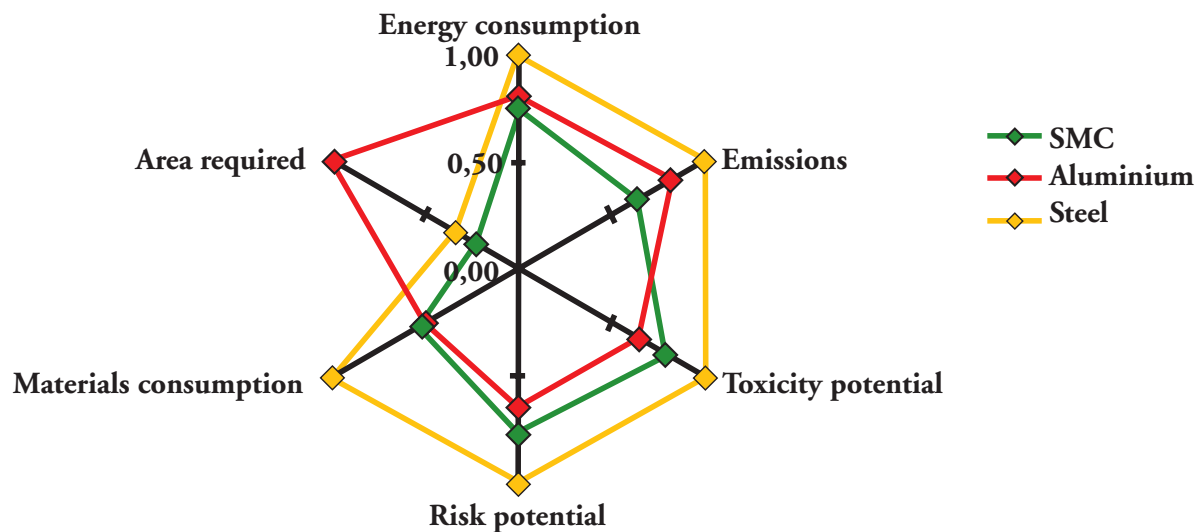

1 = greatest effect on the environment,

0 = smallest effect on the environment

“SMC parts have, the lowest energy consumption, the lowest emissions and area requirements with the smallest impact foot print.”

STEP-BY-STEP ASSEMBLY TANKS

FROM 1 TO 10,000M³ (260-2,500,000 USG)

Despite its' great strength, FRP is lightweight – just 1/3 one third the weight of an equivalent steel panel. All panels can be lifted by hand, with no special equipment required even where access is difficult, and installation can progress quickly and efficiently.

- Step 1.** Install steel footings on leveled concrete foundations.
- Step 2.** Align FRP panels to be pre-assembled.
- Step 3.** Place rubber sealant from ready-to-use roll between panels..
- Step 4.** Connect panels with bolts and nuts.
- Step 5.** Position bottom panel sections, and finish up base of tank.
- Step 6.** Position three sides of the tank, leaving one vertical row per side open.
- Step 7.** Position and fix roof panels and if required, roof support pipes and plates.
- Step 8.** Install reinforcement if required.
- Step 9.** Close up the tank with the fourth side.
- Step 10.** Finish the internal or external reinforcement.
- Step 11.** Fill and test.

P.S. Installation CD and Manual will accompany large tank orders.



Step 1



Step 2



Step 3 & 4



Step 5



Step 6



Step 7



Step 8 & 9



Step 10



Step 11

One of the largest **FTC** FRP Panel Tanks in the world, capacity:
US Gallons 2,500,000 (10,000m³)

CONVENIENT SELF-ASSEMBLY KITS

FROM 1 TO 18M3 (260 TO 4,750 USG)

SIMPLICITY OF HANDLING

The most widely used tank sizes for private customers fall within the range of 1m³ to 18m³ (260 – 4,750USG).

These sizes are available as complete pre-packed kits on pallet, containing all panels and accessories required, and a simple step-by-step self assembly manual.

No special tools are required, and assembly may be completed without the services of a specialist contractor.



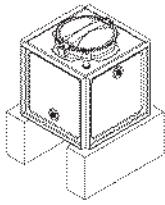

$1 \times 1 \times 1 = 1m^3$
 $3.3 \times 3.3 \times 3.3 = 264 \text{ USG}$

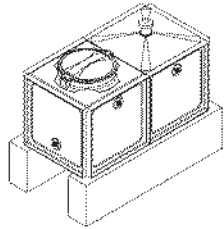

$1 \times 2 \times 1 = 2m^3$
 $3.3 \times 6.5 \times 3.3 = 528 \text{ USG}$

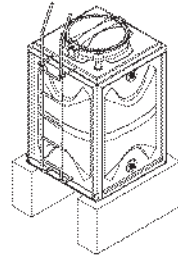

$1 \times 1 \times 1.5 = 1.5m^3$
 $3.3 \times 3.3 \times 4.9 = 396 \text{ USG}$

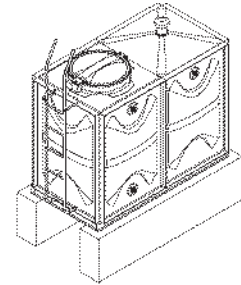

$1 \times 2 \times 1.5 = 3m^3$
 $3.3 \times 6.5 \times 4.9 = 793 \text{ USG}$

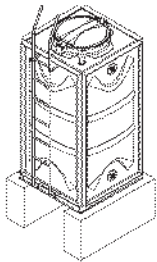

$1 \times 1 \times 2 = 2m^3$
 $3.3 \times 3.3 \times 6.5 = 528 \text{ USG}$

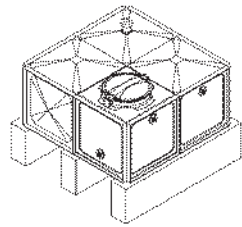

$2 \times 2 \times 1 = 4m^3$
 $6.5 \times 6.5 \times 3.3 = 1,057 \text{ USG}$

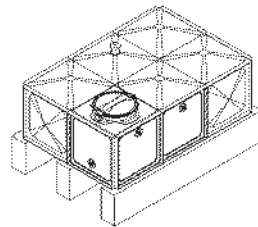

$3 \times 2 \times 1 = 6m^3$
 $9.8 \times 6.5 \times 3.3 = 1,585 \text{ USG}$

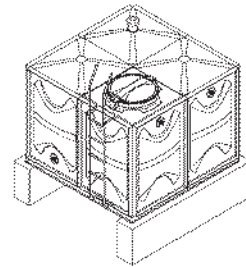

$2 \times 2 \times 1.5 = 6m^3$
 $6.5 \times 6.5 \times 4.9 = 1,585 \text{ USG}$

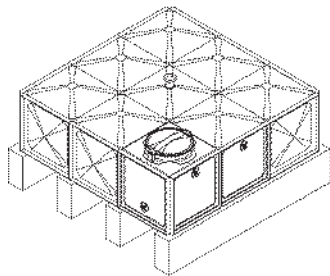

$3 \times 3 \times 1 = 9m^3$
 $9.8 \times 9.8 \times 3.3 = 2,378 \text{ USG}$

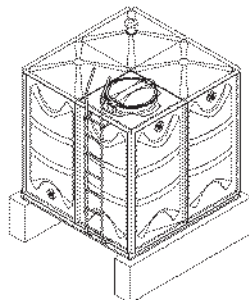

$2 \times 2 \times 2 = 8m^3$
 $6.5 \times 6.5 \times 6.5 = 2,114 \text{ USG}$

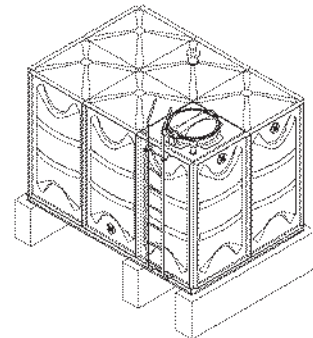

$3 \times 2 \times 2 = 12m^3$
 $9.8 \times 6.5 \times 6.5 = 3,170 \text{ USG}$

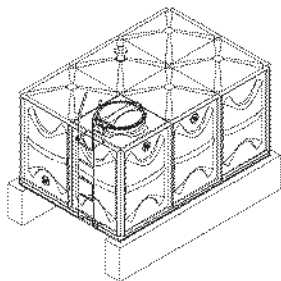

$3 \times 2 \times 1.5 = 9m^3$
 $9.8 \times 6.5 \times 4.9 = 2,378 \text{ USG}$

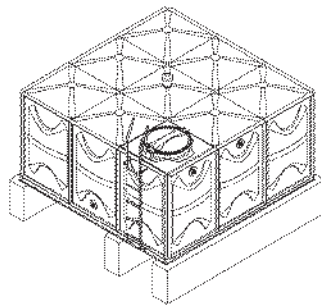

$3 \times 3 \times 1.5 = 13.5m^3$
 $9.8 \times 9.8 \times 4.9 = 3,567 \text{ USG}$

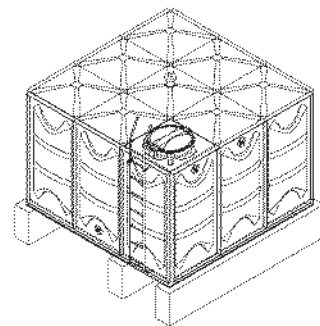

$3 \times 3 \times 2 = 18m^3$
 $9.8 \times 9.8 \times 6.5 = 4,755 \text{ USG}$

PERFECT FLEXIBILITY

A SYSTEM ADAPTING TO EVERY NEED

The **FTC** FRP Panel Type Water Tank system is designed for every need, from 1m³ to 10,000m³ (260 – 2,500,000USG). Small to medium units provide intermediate or reserve tanks supplied from a municipal piped delivery system, for installation in private homes, hotels, hospitals, offices and other building complexes.

Medium to larger units form back-up supplies to key services, industrial, commercial complexes, municipalities and irrigation schemes. Units of almost any size provide primary sources of pure and clean water, wherever constant piped supply may not be available.

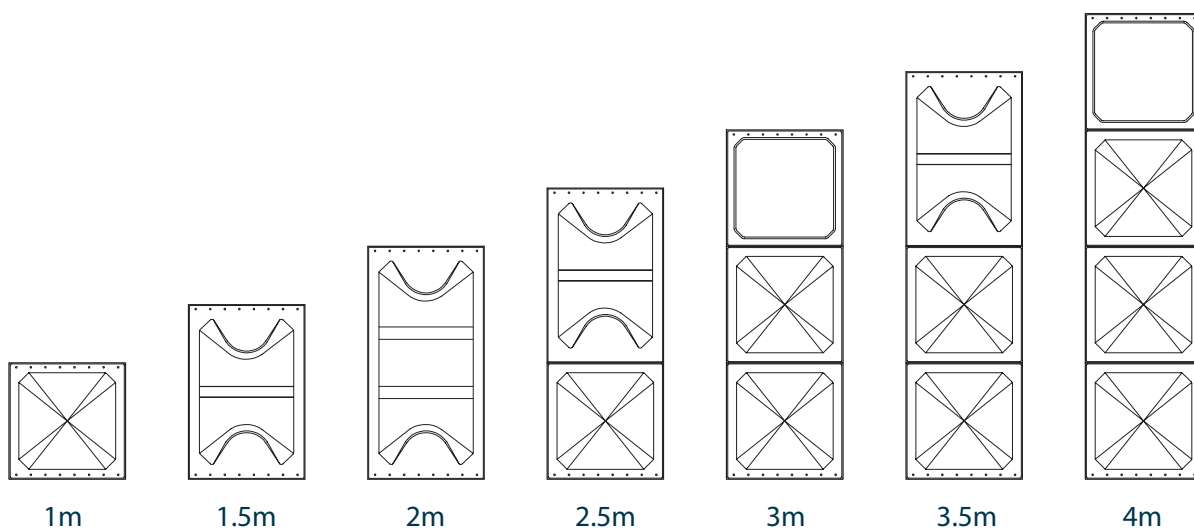

Stocking Item

INDIVIDUAL PANEL DESIGN

The panel tank is modular system, with panel sizes from 0.5 to 2 meter (1.65 to 6.5 feet) in height. Unlike more traditional units in steel or concrete, the panels are formed from hot pressed FRP (fiber reinforced plastic).

This modern form of construction has a number of significant advantages corrosion free; free from algae accumulation; highly durable; exceptional strength to weight ratio; ease of assembly. The panels are individually designed according to their different functions and positions in the tank, to achieve maximum strength and functional efficiency.

By combining panels as appropriate, a tank of any desired capacity and shape may be constructed, to adapt to any restrictions at the site. Should it be necessary to increase the capacity of the tank at some time in future, this may be achieved without problem or wastage, by simply adding additional panels. In the same way, the entire tank may even be relocated if required, by disassembling and reconstructing at the new location.

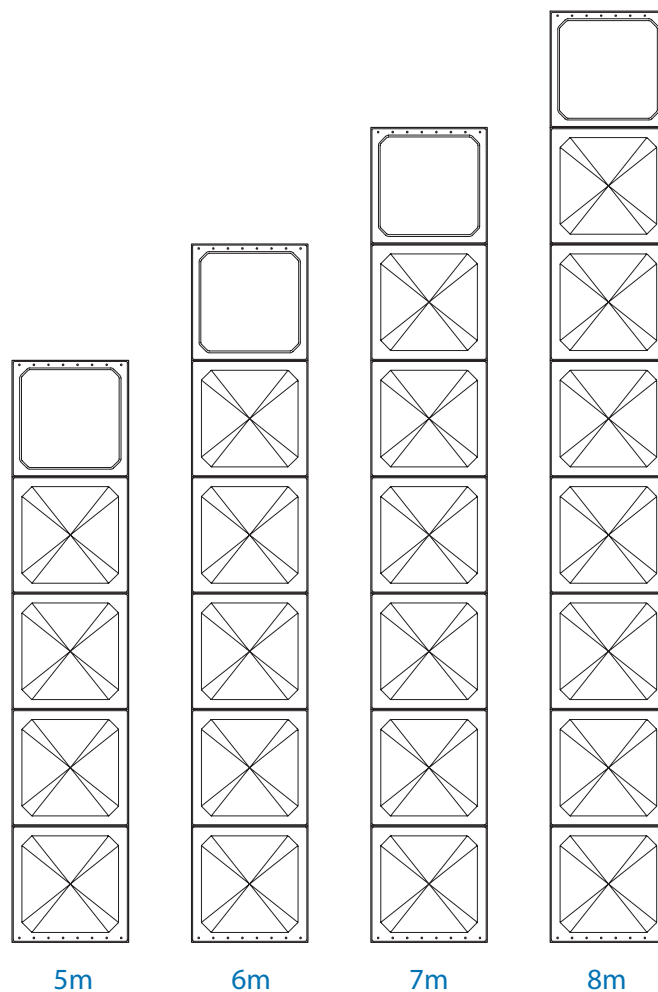

Custom Design Per Project

STANDARD PANEL PATTERNS

SINGLE TIER TANKS

(1 meter, 1.5 meter, and 2 meter high tanks)

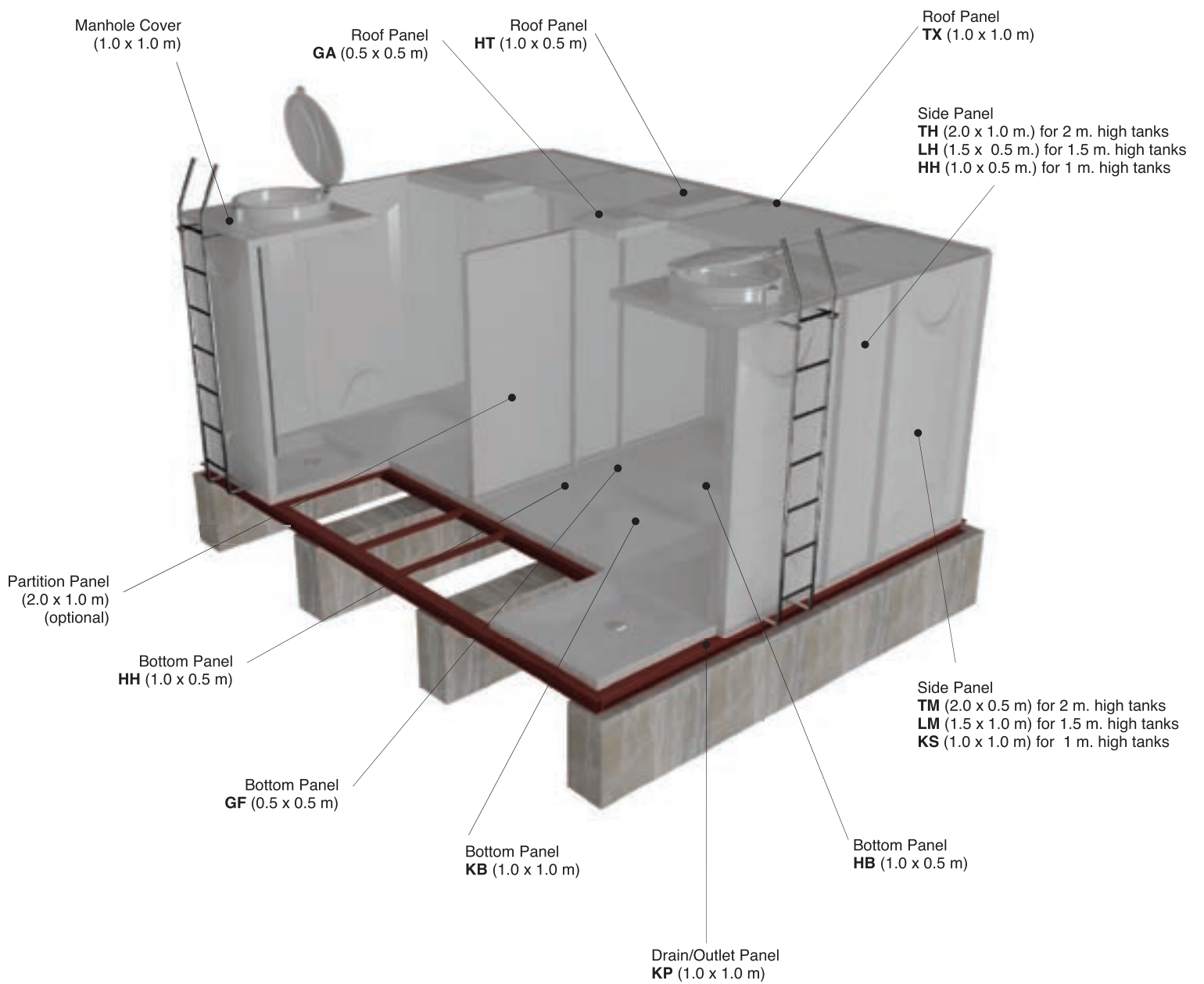

MULTIPLE TIER TANKS (2.5 meters and more)

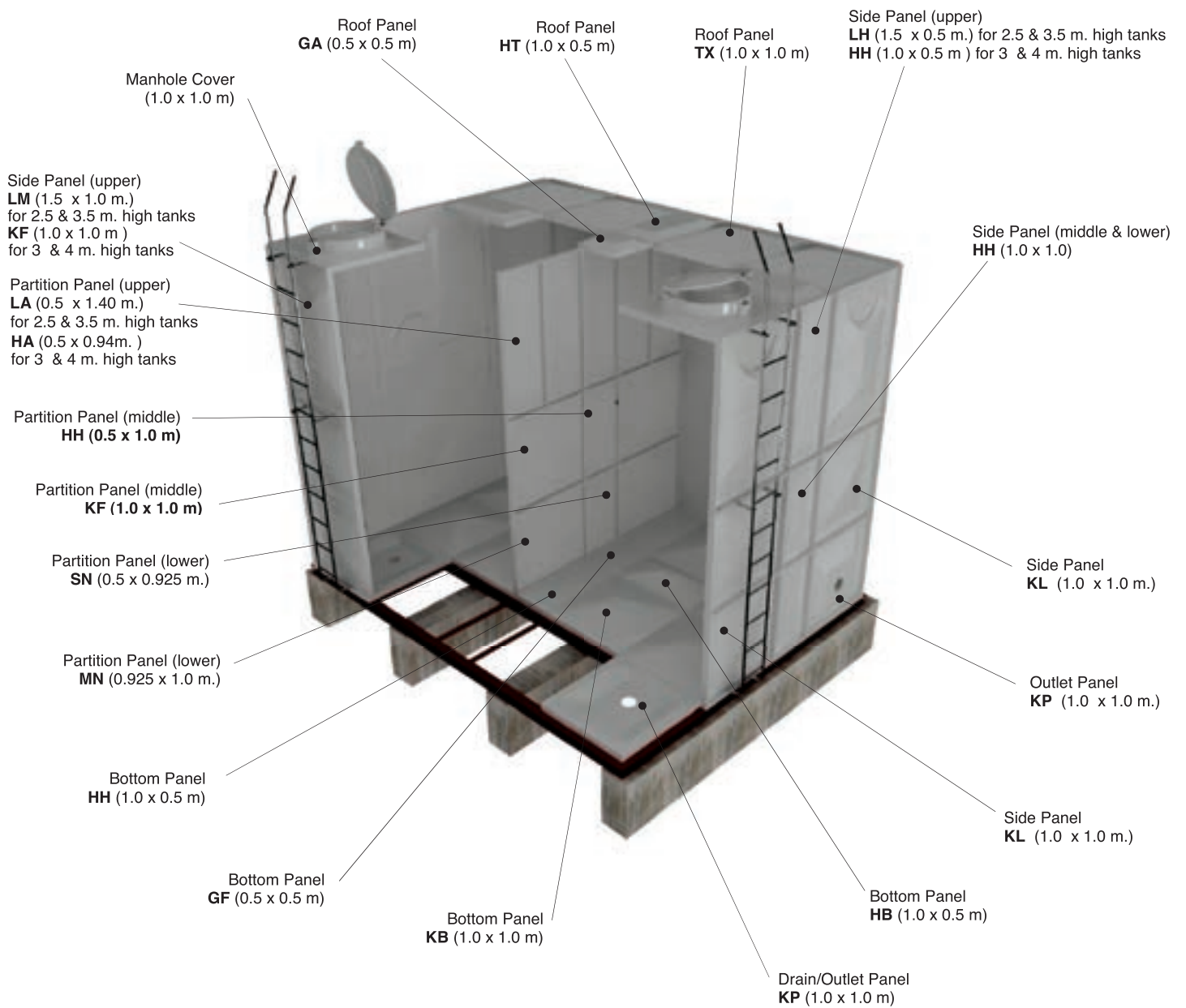

TECHNICAL DATA

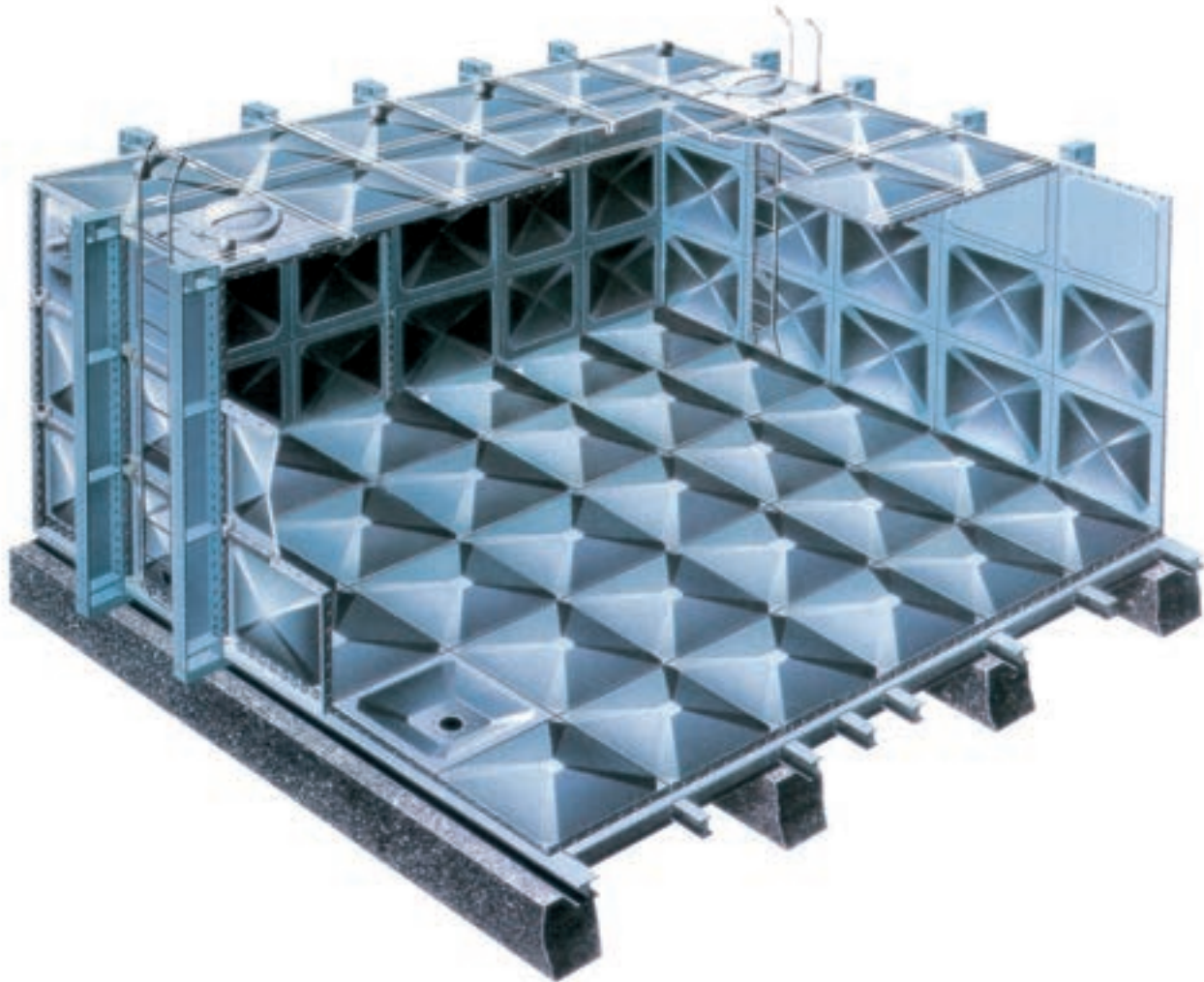

FTC FRP PANEL TYPE TANKS

Hot pressed FRP panel water tanks were first used in the early 1970's. The substantial advantages over more traditional systems – durability and reliability; corrosion and contamination free; weight to strength ratio; flexibility of size and shape; ease of assembly – soon proved this to be the ideal system for storing clean drinking water in all climates. Routine maintenance is also reduced to a practical minimum. External flanges on sides and base mean that most inspection and maintenance can be carried out from outside, and low thermal expansion coefficients minimize stress in the complete structure.

PANEL MATERIAL PROPERTIES

DESCRIPTION	FRP
Specific gravity	1.8
Glass content	more than 40%
Tensile strength	100 MPa (14,500 psi)
Young's modulus	13,749 MPa (1,991,268 psi)
Flexural strength	165 MPa (29,900 psi)
Impact strength	51.4 KJ/m ² (24.5 lbf - ft/in ²)
Compressive strength	295 MPa (13,500 psi)
Shear strength	93 MPa (13,500 psi)

PANEL MATERIAL CHARACTERISTICS

	Components	Material
Panel	FRP Panel	FRP
Joints	Sealant	Synthetic rubber
	Bolts & nuts	Structural Steel Galvanized and/or Stainless Steel
Reinforce- ment	Roof support	uPVC and/or polyurethane
	External reinforcing	Structural Steel Galvanized

THERMAL PROPERTIES

DESCRIPTION	FRP
Thermal expansion	$2.16 \times 10^{-5} / ^\circ\text{C}$
Thermal conductivity	(Single Panel) 0.15 Kcal/m hr °C (630 J/m hr °C)
	(Insulated Panel) 0.02 Kcal/m hr °C (84 KJ/m hr °C)
Coeff. of overall heat transmission	(Single Panel) 5.0 Kcal/m ² hr °C (21 KJ/m ² hr °C)
	(Insulated Panel) 1.0 Kcal/m ² hr °C (4.2 KJ/m ² hr °C)
Water absorption	less than 0.2%
Cavity	less than 2%
Light transmittance	Gray 0.00%

THERMAL TRANSMISSION

	Coeff. of overall thermal transmission Kcal/m ² hr °C (KJ/m ² hr °C)	
	Air-Panel-Air	Water-Panel-Air
STEEL	14.3 (59.9)	24 (100)
FRP (Standard)	3.0 (13.0)	5 (21)
FRP (Insulated)	0.9 (3.8)	1 (4)

THERMAL CONDUCTIVITY

	Thermal conductivity Kcal/m hr °C (KJ/m hr °C)
STEEL	37.0 (1.55 x 10 ⁵)
FRP (Standard)	0.15 (630)
FRP (Insulated)	0.02 (84)

STEEL FOOTING DESIGN

FTC FRP Panel Type Water Tanks must be supported on steel footings, which are level and free from deformation. The footings should be anchored on concrete foundations (see next pages). Recommended steel footing specifications are shown below

DIMENSION OF STEEL BEAMS

Tank Height		Reinforcement	Main Beam "a"	Sub Beam "b"
1 m	3.3 ft	Ext.	CC 100x50x5	SA 50x50x5
1.5 m	4.9 ft	Ext.	HB 100x100x8	SA 65x65x6
2 m	6.5 ft	Ext.	HB 100x100x9	SA 65x65x7
2.5 m	8.2 ft	Ext.	IB 200x100x7x5	IB 200x100x7x5
				SA 75x75x9
3 m	9.8 ft	Ext.	IB 200x100x7x5	IB 200x100x7x5
				SA 75x75x9
3.5 m	11.5 ft	Ext.	IB 200x100x7x5	IB 200x100x7x5
				HB 100x100x8
4 m	13.1 ft	Ext.	IB 200x100x7x5	IB 200x100x7x5
				HB 100x100x8
5 m	16.4 ft	Ext.	IB 200x100x7x5	IB 200x100x7x5
				HB 100x100x8

NOTES:

1. The interval between support points should not exceed 2 meters / 6.5 feet for main beams 'a' and 1 meter or 3.3 feet of sub beam 'b'. See following page for location of main and sub teams.
2. Welding of the steel footings framework is acceptable.
3. Maximum allowable deflection 5mm, 1/5 inch.
4. For tanks longer than 10 meters/ 33 feet, your **FTC** representative should be consulted concerning the footing design.

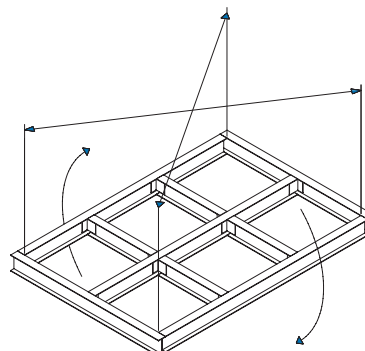
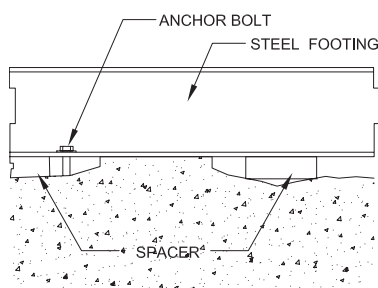

The steel footing framework should be flat and free from any twisting. Diagonals should be checked for equal length to ensure accurate rectangular shape

Shown below are the steel footing arrangement of main beams (shown red) and sub beams (shown blue) and its' positioning on concrete foundations.

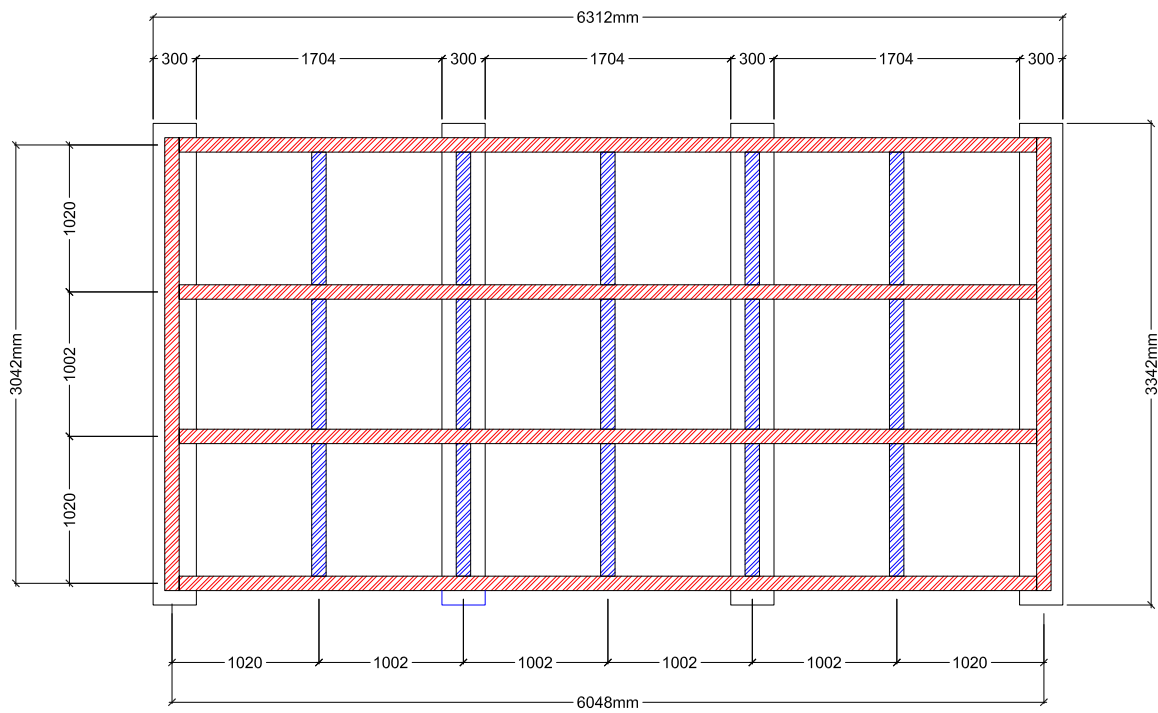

CONCRETE FOUNDATIONS

LOCATION OF CONCRETE FOUNDATION AND STEEL FOOTING

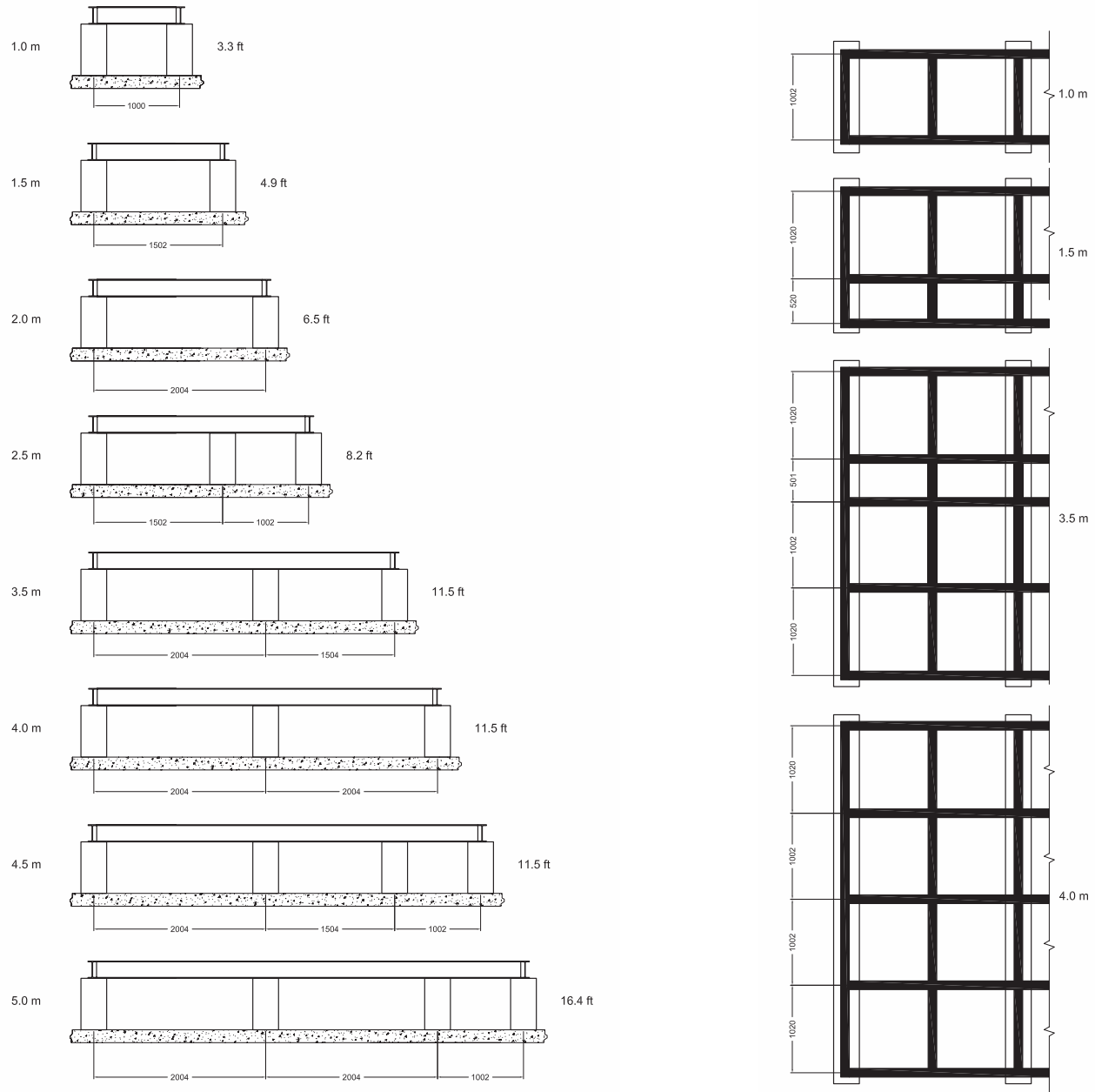

Detail dimensions of tank and pipework connections

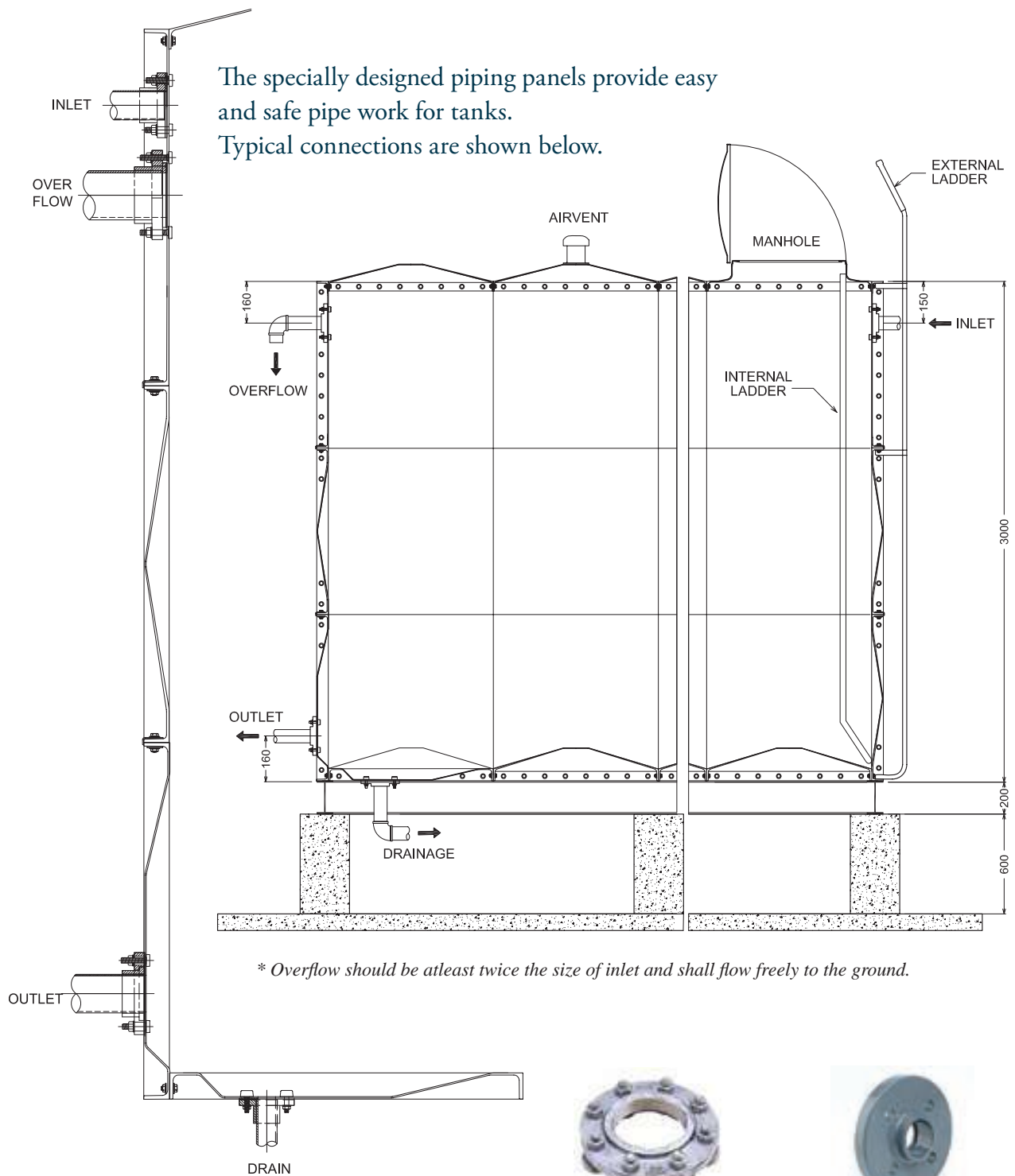

SCREWED STEEL FLANGE



PVC FLANGE

FLANGE DIMENSIONS FOR TANK CAPACITIES

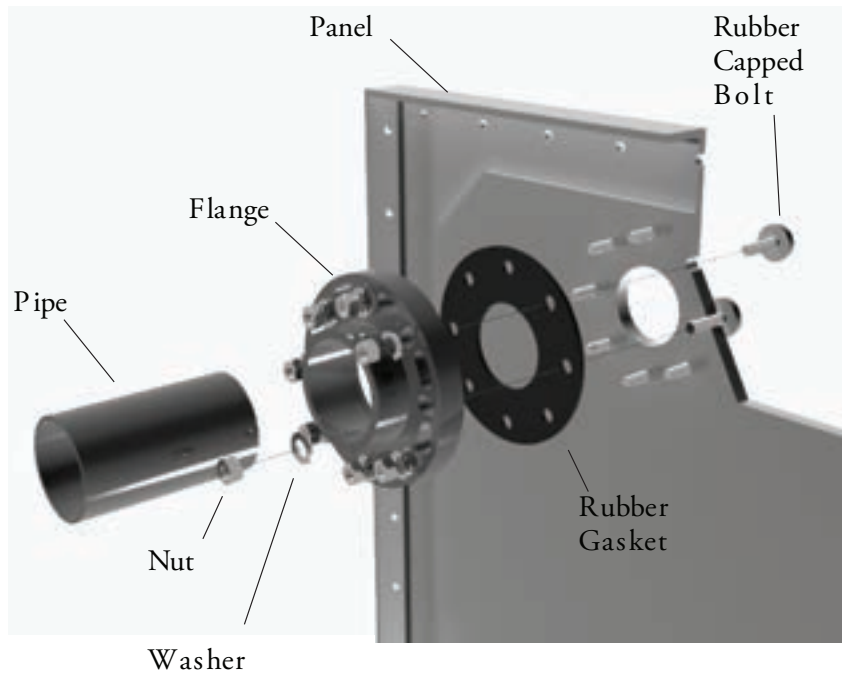

FTC RECOMMENDED FLANGE SIZES

Size of Tank		Inlet		Outlet		Overflow		Drain	
1m ³ -5m ³	Up to 1,300 USG	25A	1"	50A	2"	65A	2½"	40A	1½"
6m ³ -10m ³	Up to 2,600 USG	40A	1½"	65A	2½"	65A	2½"	40A	1½"
11m ³ -20m ³	Up to 5,300 USG	40A	1½"	65A	2½"	65A	2½"	40A	1½"
21m ³ -50m ³	Up to 13,200 USG	50A	2"	80A	3"	80A	3"	40A	1½"
51m ³ -100m ³	Up to 26,500 USG	80A	3"	100A	4"	125A	5"	50A	2"
101m ³ -200m ³	Up to 53,000 USG	80A	3"	150A	6"	125A	5"	50A	2"
201m ³ -500m ³	Up to 132,000 USG	100A	4"	200A	8"	150A	6"	80A	3"
Over 500m ³	Over 132,000 USG	100A	4"	200A	8"	150A	6"	80A	3"

TYPES OF FLANGES

MATERIAL		STANDARDS	FIT	GASKETS
PVC	Brass	ASA/ANSI	Fixed	EPDM
CPVC	Stainless Steel	NSF	Rotatable	Viton®
FRP	Galvanized Steel	ISO	Expansion	



Marking Flange Hole and Bolt holes at relevant location



Drilling Flange hole

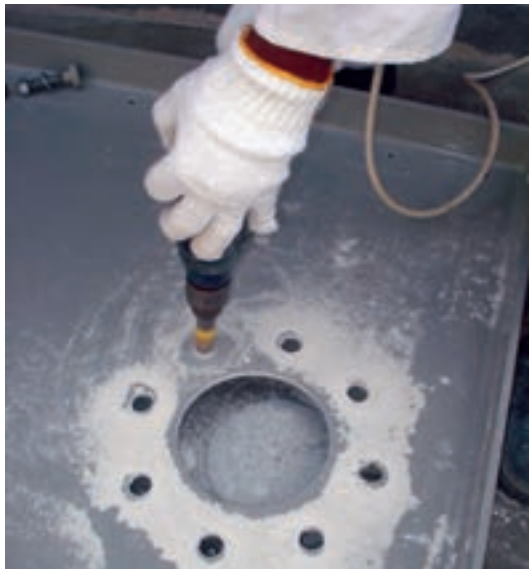

Drilling Bolt holes



Fitting Flange with Rubber, Gasket and Rubber Capped Bolts

PICTURES GALLERY



Seawater Intake Tank at Desalination Plant



Elevated Potable Water Storage Tank



Conditioning Tank for RO Desalinated Water



Conditioning Tank for RO Desalinated Water



Fire Tank at Crude Oil Pumping Station



Potable Water Storage at Rural School



Water Storage for Cooling System at Data Center



Rural Potable Water Storage Tank

STEEL TOWERS FOR ELEVATED TANKS

The **FTC** FRP Panel Type Water Tank is particularly well suited for installation on a steel tower, where a free standing elevated unit is required to supply a permanent head of water.

Where desired, suitable towers of a truss or lattice construction can be designed and supplied, in a form suitable for container shipment. In nearly all such cases, major savings in time and labor required to complete the project will be achieved, compared to traditional installations. Towers of this construction can be supplied for all sizes of unit.

Recommended standard design criteria are shown opposite. However, all concrete foundation work for towers must be specified locally, based on local site conditions, to comply with loading and regulatory requirements, and, where appropriate, seismic requirements.

Steel footings to support and anchor the tank on the tower should be constructed in accordance with the standards set out on the previous pages.

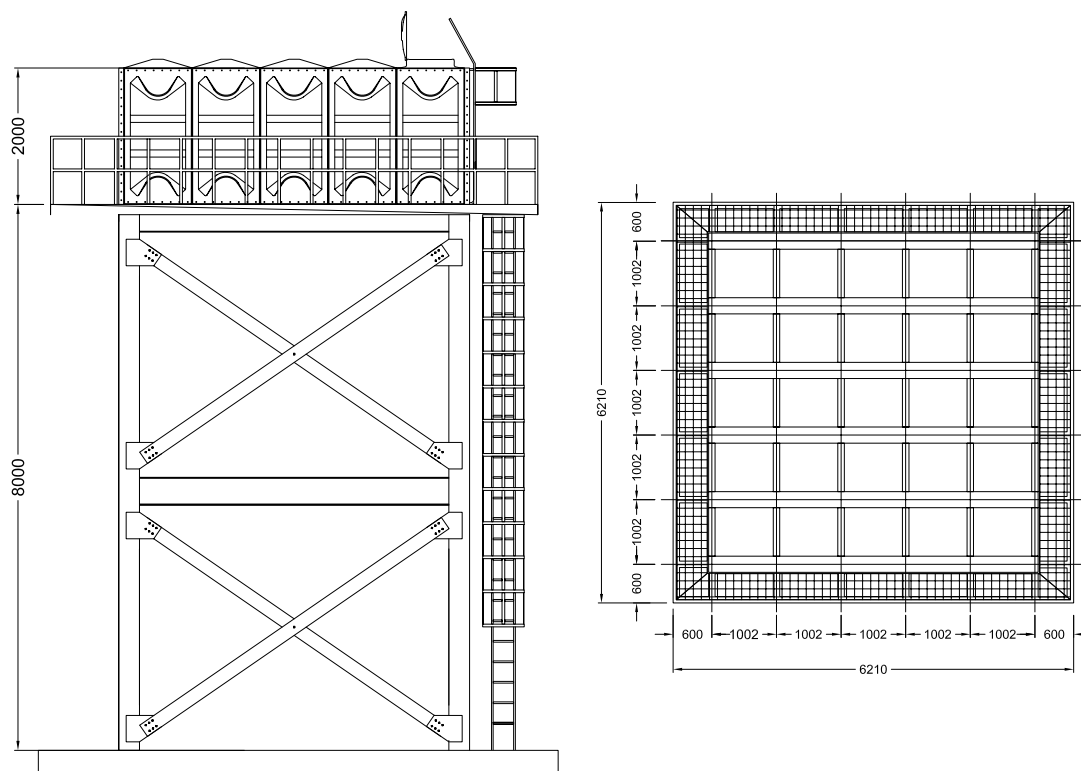

DESIGN CRITERIA SITE CONDITION FACTORS

Wind velocity	60m/sec. (134mph)
Allowable strength (short term)	
• Steel tensile	2.4 ton /cm ² (33,650Psi)
• Concrete (compressive cm ²)	0.18 ton.cm ² (2,517Psi)
• Anchor bolt high tension	10 ton/cm ² (140,100Psi)
Seismic coefficient	K=0.3G

SITE CONDITION FACTORS

Local conditions must be established in order to determine:

1. Allowable soil load bearing pressure
2. Seismic load coefficient
3. Maximum wind velocity
4. Snowlead

(For more severe earthquake conditions the factor can be increased up to 1.0G)

FTC Panel Type Water Tanks towers are designed using latest steel technology and specifications, to meet internationally accepted standards for static and dynamic seismic loads.

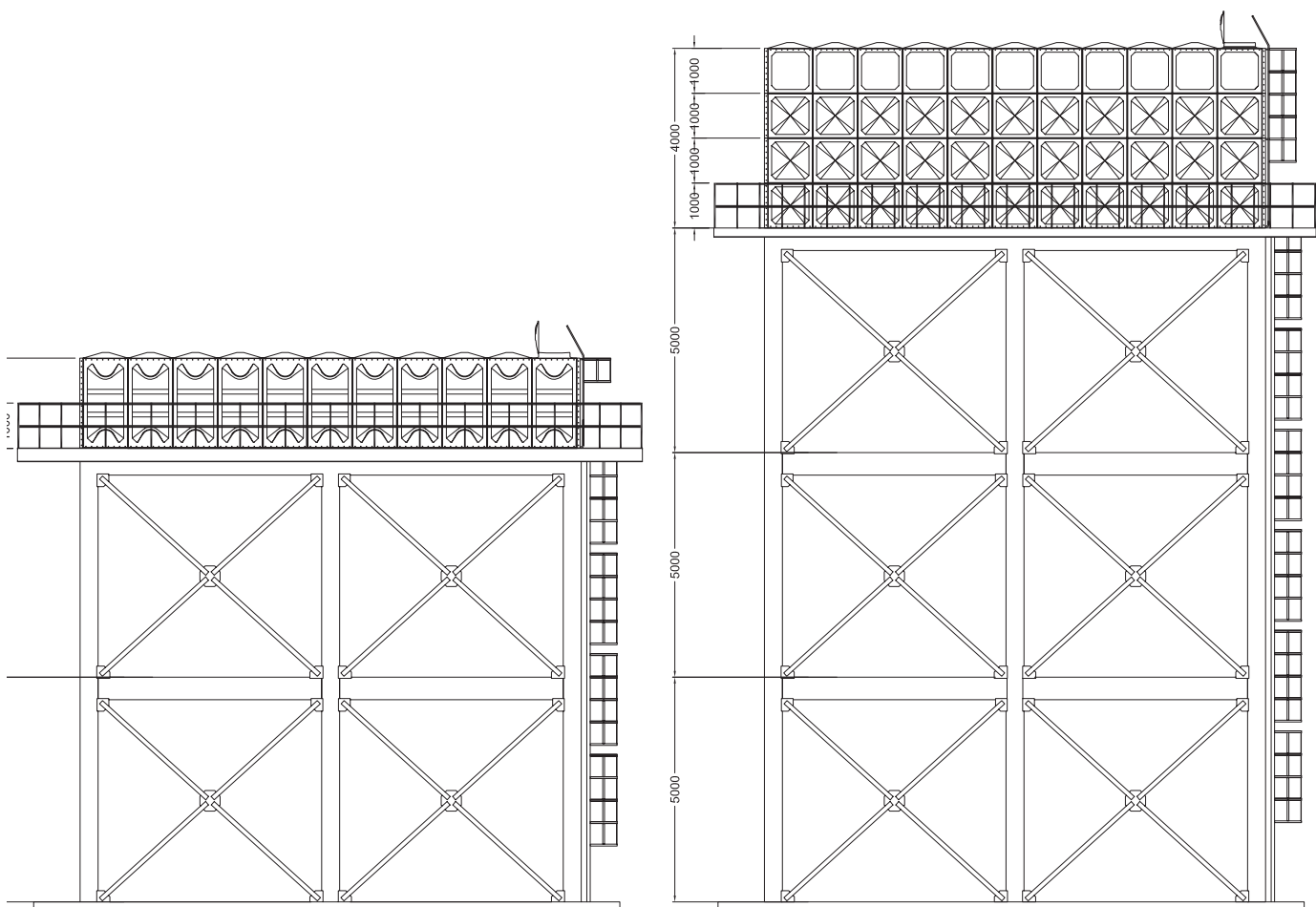

COMPONENTS AND ACCESSORIES

Corner Angle & Frame Angle
Material: Hot Dipped Galvanized

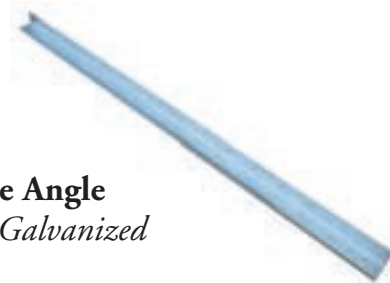

Rubber Capped Bolt for Flange
*Material: Hot Dipped Galvanized / Stainless Steel
+ Synthetic rubber*



Bolts and Nuts for Panels
Material: Hot Dipped Galvanized / Stainless Steel





Airvent
Material: uPVC



Internal Ladder
Material: uPVC
FRP
Stainless Steel



External Ladder
Material: Hot Dipped Galvanized
Stainless Steel



Roof Support Pipe
Material: uPVC / PU
GRP / PU



Diagonal Strut with Accessories
Material: Hot Dipped Galvanized (outside)
Stainless Steel (inside)



SPECIAL RUBBER SEALANT
Material: Synthetic rubber
SEBS - "O" Ring type

FTC FRP Panel Type Water Tanks SERVING THE WORLD with pure, clean water

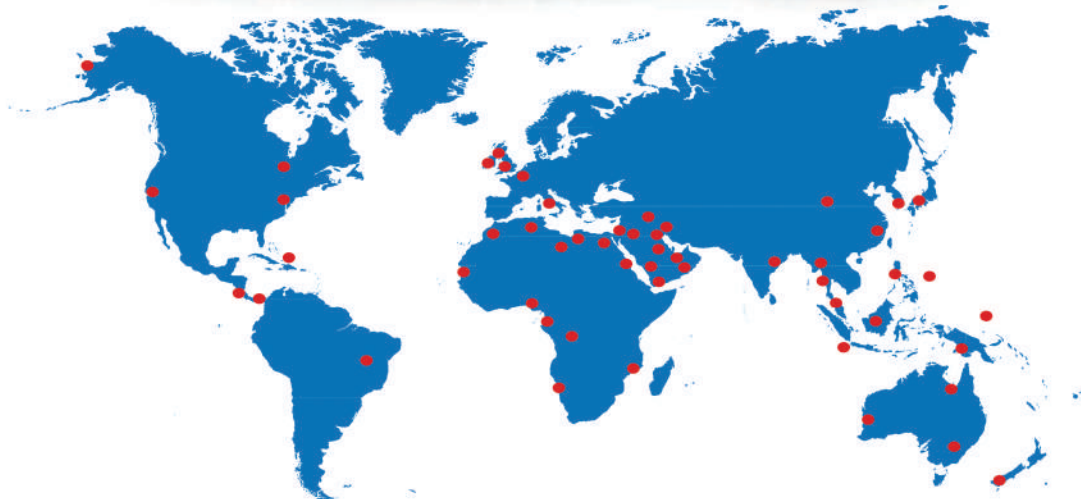

For The American Continent

DISTRIBUTION CENTER
FTC Tanks LLC
Office: Alexandria, Virginia, USA
Warehouse: Lorton, Virginia, USA
Tel : +1 (703) 637-0514 | +1 (703) 339-9605
Email : info@ftc-tanks.com | sales@ftc-tanks.com

For Europe, Africa, Asia & Australia

DISTRIBUTION CENTER
Jebel Ali, Dubai, UAE
Tel : +971 880 2860
Email : info@fiberteccorp.com

info@fiberteccorp.com

www.fiberteccorp.com

*Property and Copy rights of the subject belong to Fiber Technology Corporation, and transfer of these rights is not granted by possession of this document.
The company's policy is one of continuous product improvement; therefore, we reserve the right to make alterations to our range and specifications without prior notice.*